

PLAN VIEW

SCALE: 1"=48"

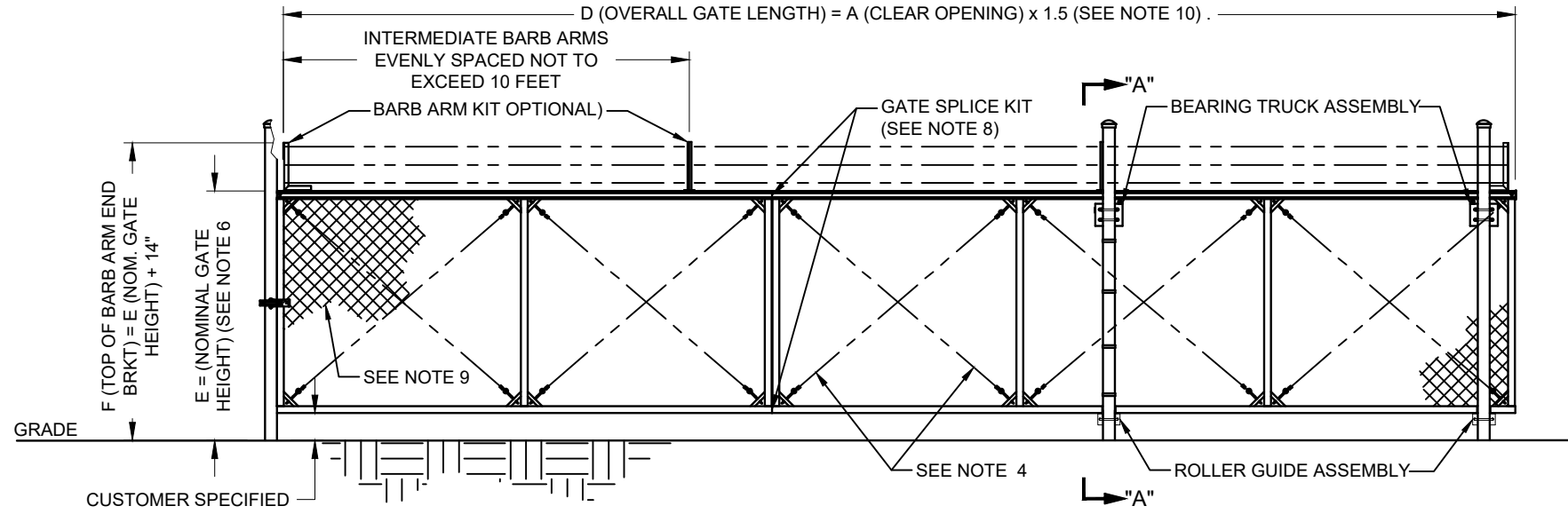

ELEVATION

SCALE: 1"=48"
UNSECURED AREA LOOKING IN

NOTES:

1. GATE OPERATOR INSTALLATION AND SAFETY STANDARD PER UL 325. (STANDARD FOR DOOR, DRAPERY, GATE, LOUVER, AND WINDOW OPERATORS AND SYSTEMS).
2. GATE FABRICATION AND SAFETY STANDARD PER ASTM F2200 (AUTOMATED VEHICULAR GATE CONSTRUCTION)
3. GATE FRAME CONSTRUCTED USING ALUMINUM 6061-T6 FOR SUPERIOR CORROSION RESISTANCE AND STRUCTURAL INTEGRITY.
4. TWO 5/16" EYE BOLT AND 3/16" STAINLESS STEEL CABLES FOR GATE FRAME ADJUSTMENT.
5. PRODUCT IS SOLD AS KITS i) GATE SEGMENT KIT, ii) HARDWARE KIT, iii) SPLICE KIT AND iv) GAP FILLER (OPTIONAL) v) BARB ARM KIT (OPTIONAL).
6. SEGMENT HEIGHT OPTIONS, 6', 7' AND 8'.
7. SEGMENT LENGTH OPTIONS 10', 12' AND 18'.
8. MULTIPLE SEGMENTS CAN BE SPLICED TOGETHER TO REACH REQUIRED OVERALL LENGTH.
9. GATE OPENING TO BE FULLY SCREENED USING GALVANIZED STEEL CHAIN LINK. MESH KIT (OPTIONAL).
10. USED FOR OPENINGS UP TO 30 FEET.



927 Alloy Drive, Thunder bay Ontario P7B 5Z8
Ph. 807-623-3352 WWW.ARMAGATE.COM

TITLE: **EC 142**
CANTILEVER ALUMINUM GATE

APPROVED BY: B. SYLVESTER	DRAWN BY: P. SCARFO	DATE: 11/FEB/20	SCALE: AS NOTED
DRAWING No: GICA-SEGMENTED-0002			SHT No.: 1 OF 2

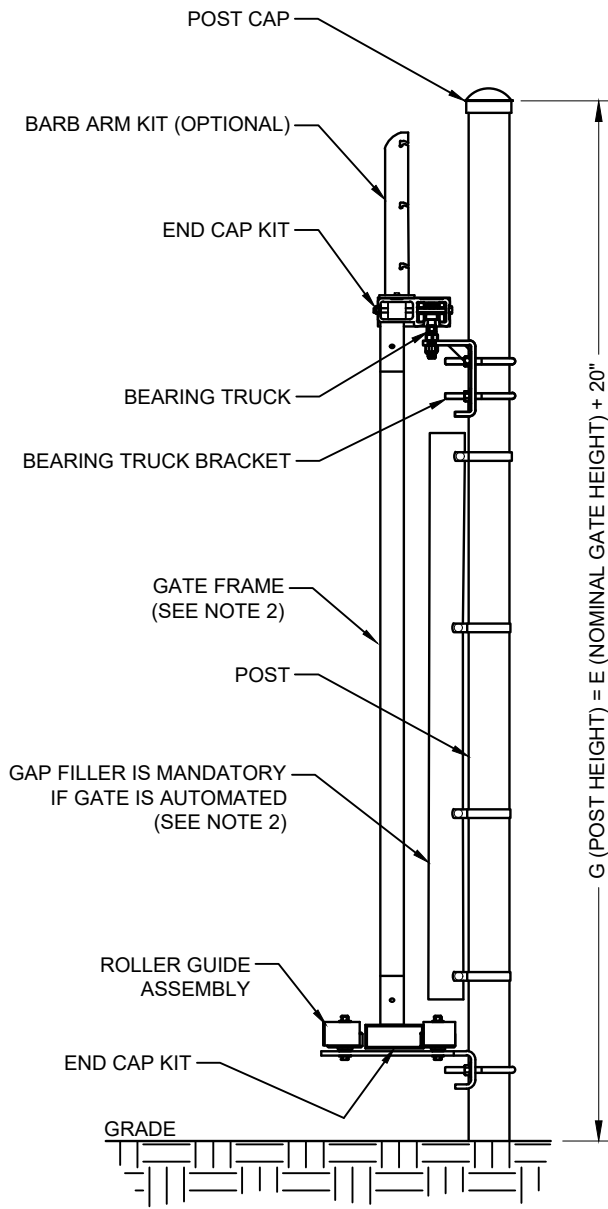

SECTION: A-A
SCALE: 1"=16"

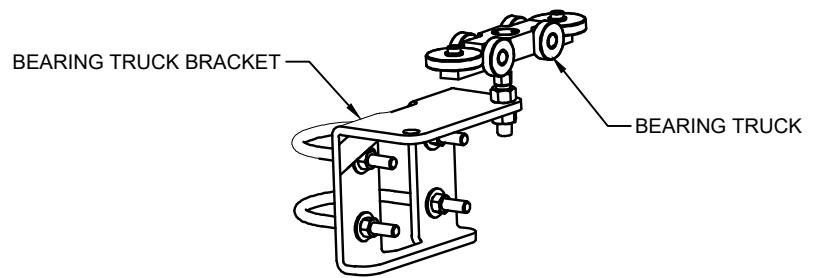

BEARING TRUCK ASSEMBLY
SCALE: NTS

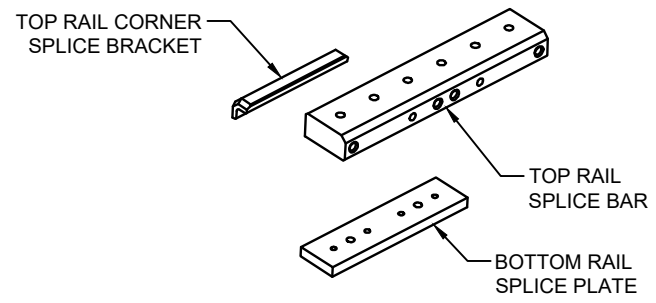

SPLICE KIT COMPONENTS
SCALE: NTS

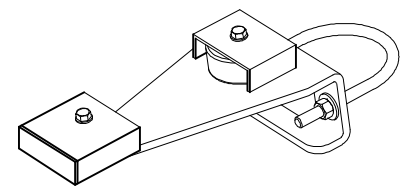

ROLLER GUIDE ASSEMBLY
SCALE: NTS

UNSECURED AREA
LOOKING IN



927 Alloy Drive, Thunder bay Ontario P7B 5Z8
Ph. 807-623-3352 WWW.ARMAGATE.COM

TITLE: **EC 142**
CANTILEVER ALUMINUM GATE

APPROVED BY: B. SYLVESTER	DRAWN BY: P. SCARFO	DATE: 11/FEB/20	SCALE: AS NOTED
DRAWING No: GICA-SEGMENTED-0002			SHT No.: 2 OF 2